

GT Plus



- Efficient built-in cabinet cooker hood
- Extract or recirculation
- 3 speed slide control
 - airflow 3 - 851 m³/hr
 - airflow 2 - 720 m³/hr
 - airflow 1 - 590 m³/hr

- Air pressure - 507 Pa
- 2 x 40w lights
- 1 washable grease filter
- Available for 60cm and 90cm widths
- Powerful tangential 240w motor
- Stainless steel, white or black

GT Plus

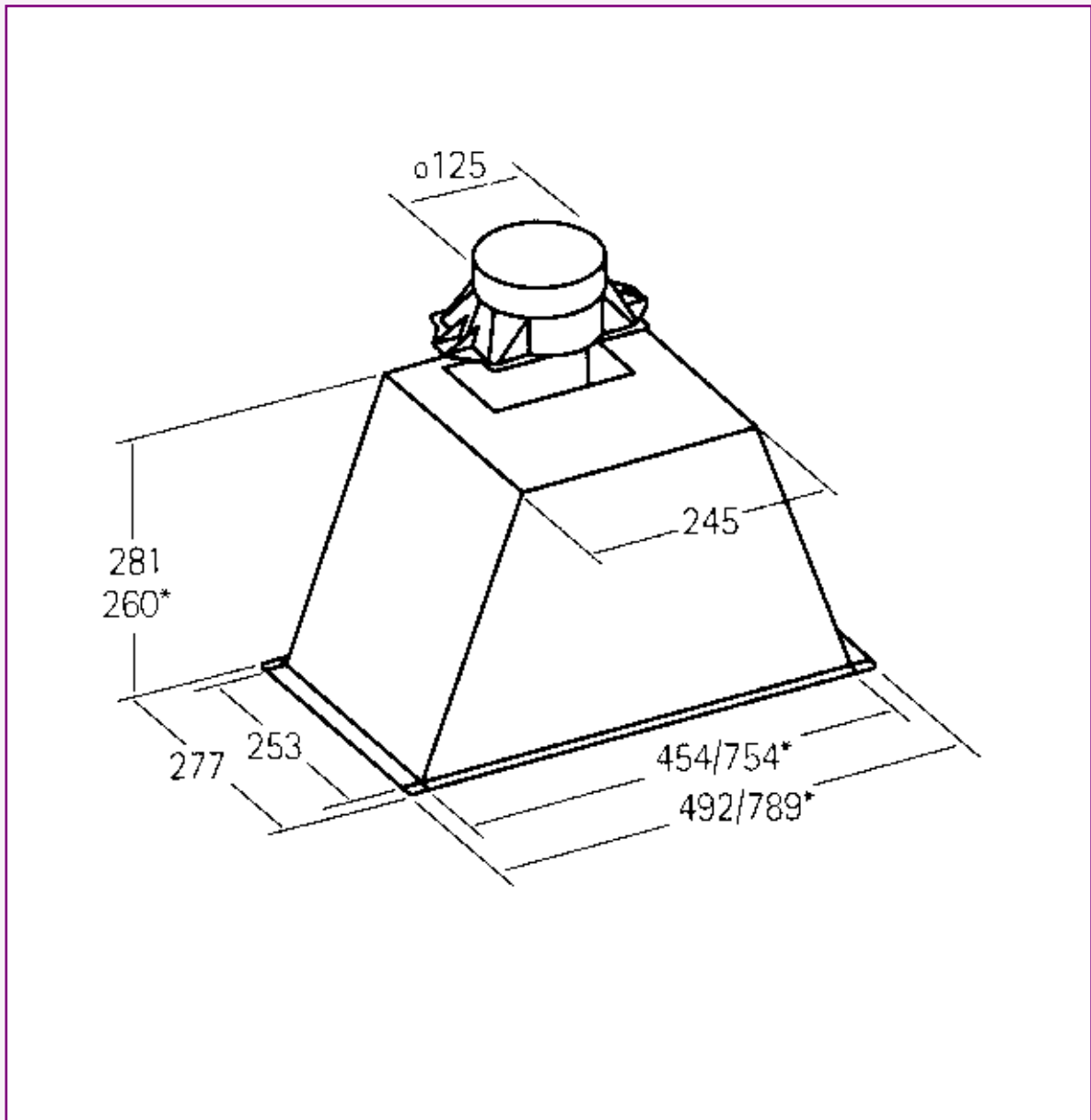

Vectaire Ltd
Lincoln Road
Cressex Business Park
High Wycombe
Bucks, HP12 3RH
Tel: +44(0)1494 522333
Fax: +44(0)1494 522337
Email: sales@vectaire.co.uk

